



**Activity:** Draw a top view and a either a side or front view of your design idea or experiment apparatus.



## What is Design?

A design is a plan or specification for the construction of an object or system. The result of that plan or specification can be in the form of a prototype, product or process.

The design usually has to satisfy certain goals and constraints, may take into account aesthetic, functional, or economic considerations, and is expected to interact with a certain environment. Major examples of designs include architectural blueprints, engineering drawings, detail drawings, concept drawings as well as sketches, renderings or artist impressions.

## Design Drawings

Design drawings are typically aesthetic drawings or renderings that represent possible solutions. Drawings are typically the first step in the design phase.

## Design Activities

In some cases, constructing an object first, without plans may also be considered to be a design activity.

## Aim of my experiment:

Find out how wide a pile of regolith will be when the pile is high enough to cover a dome measuring 400mm high (plus 20mm regolith cover)

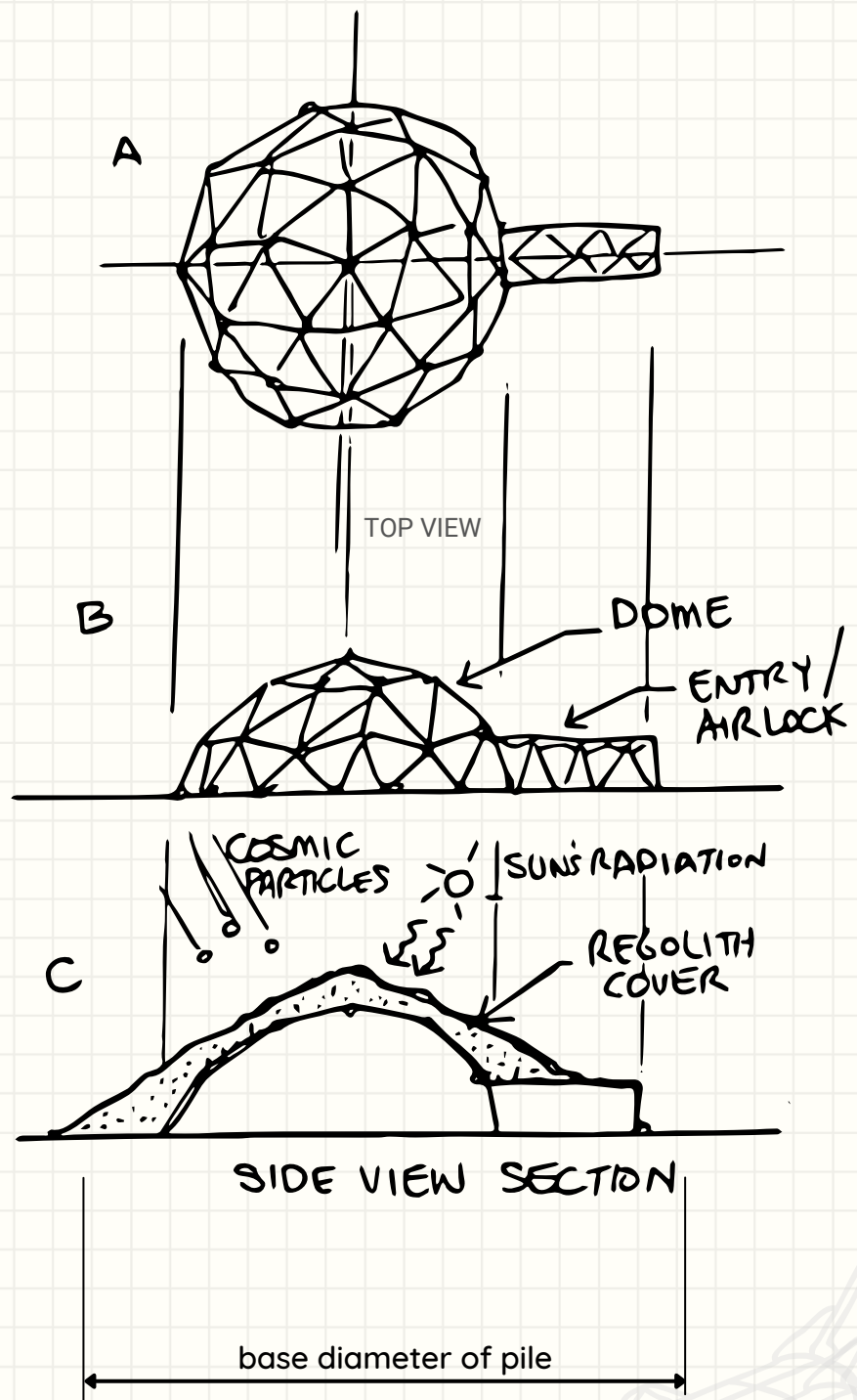

FRONT/SIDE VIEW



## Activity: Pictorial views

Practise sketching one small part of your design as a pictorial view. Alternatively, sketch any object that travels into space.



Sketching pictorial drawings at [www.iteachstem.com.au](http://www.iteachstem.com.au)



Bottle rockets drawn using a template.

My design for a robot that can scoop up the lunar regolith, to help cover the dome habitats.

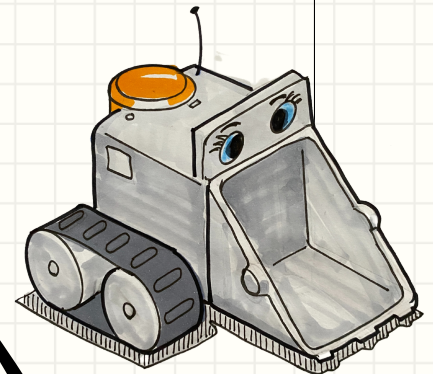
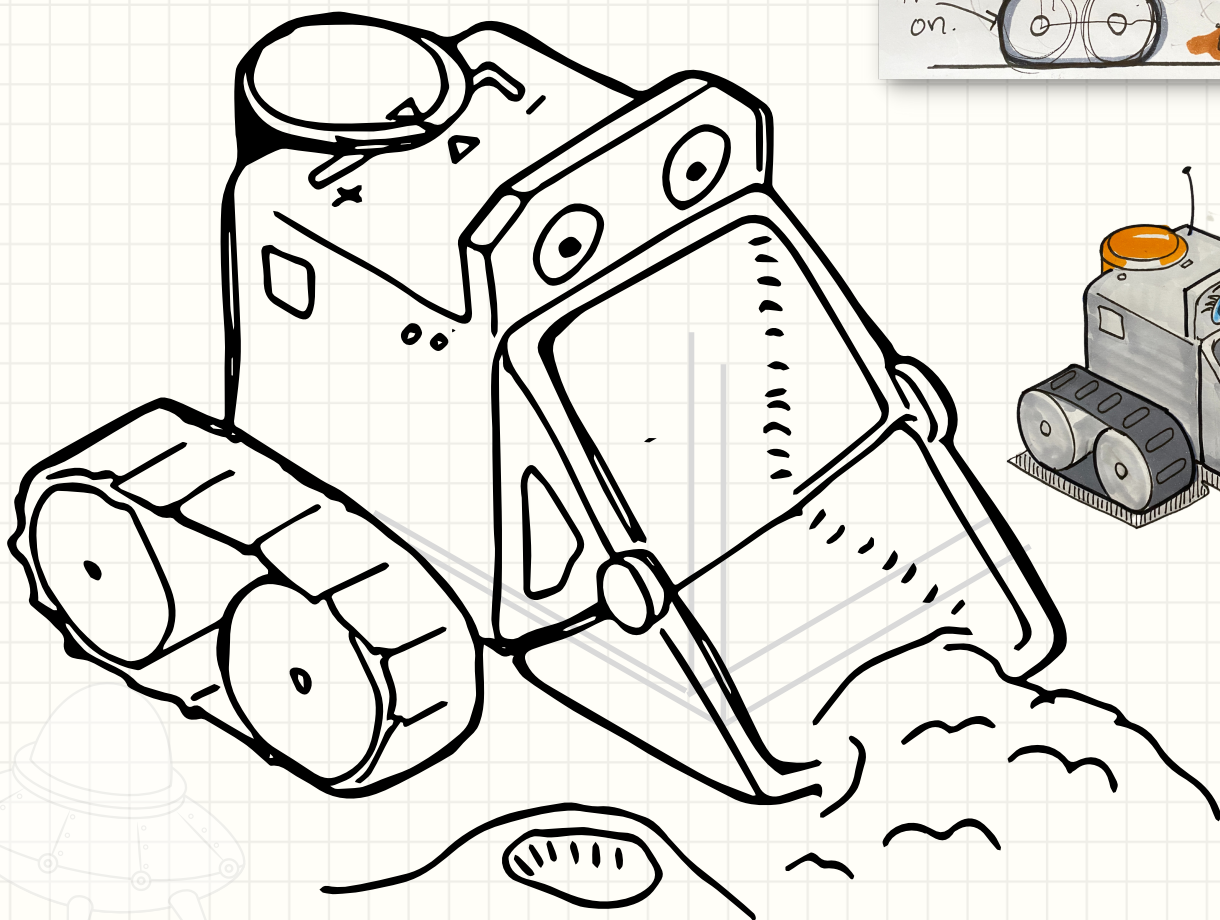

ISOMETRIC VIEW

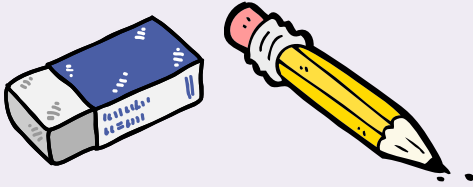
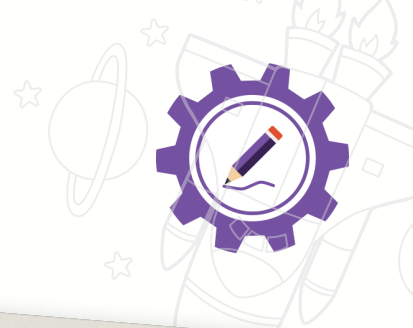

## Rendering

Rendering is the process of creating the effects of light, shade and light source to achieve contrast in drawings. rendering improves the quality of line drawings. while line drawing indicate more of the shape than the form of an object drawn, rendering improves the quality of the drawing so as to give it a photo- realistic quality.

## Colouring vs Rendering

Colouring = Coloured "in the lines", or put colour in the areas they belong.

Rendering = Making the image really pop, by adding shading and details so it looks more polished and professional.

## Annotations

Annotations are brief, written explanations provided with design deliverables in order to define & describe aspects of the design.



Watch the [video](#) by Splat 3D on how to produce annotated and rendered drawings such as those to the right/top.

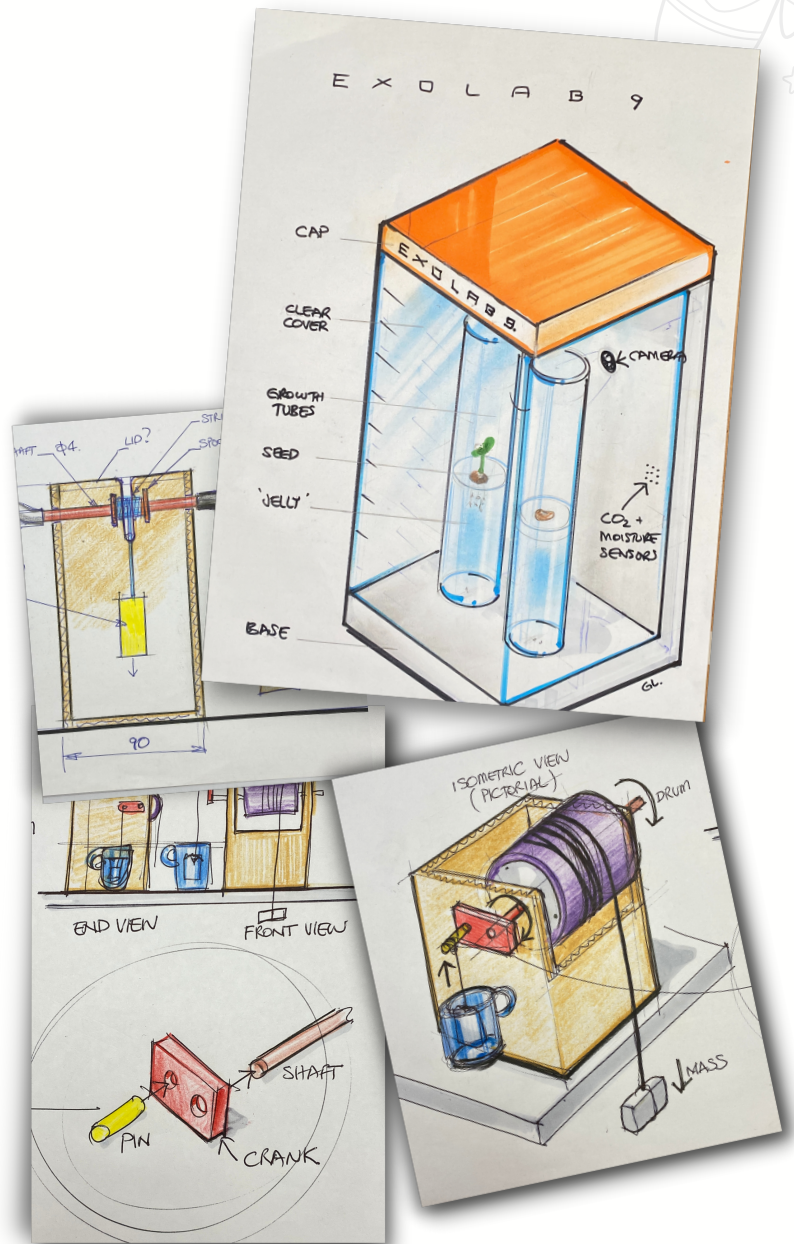

**Above:** Design drawings for mechanical devices.

**Below:** Click on any of the five core 3D objects for a demonstration of how to render them.



Annotate your design using notes with arrows. Explain the highlights of your design.

Identify the materials in your design.



**Activity:** Using the isometric grid below try drawing/sketching a more detailed example of your design. Include some measurements.

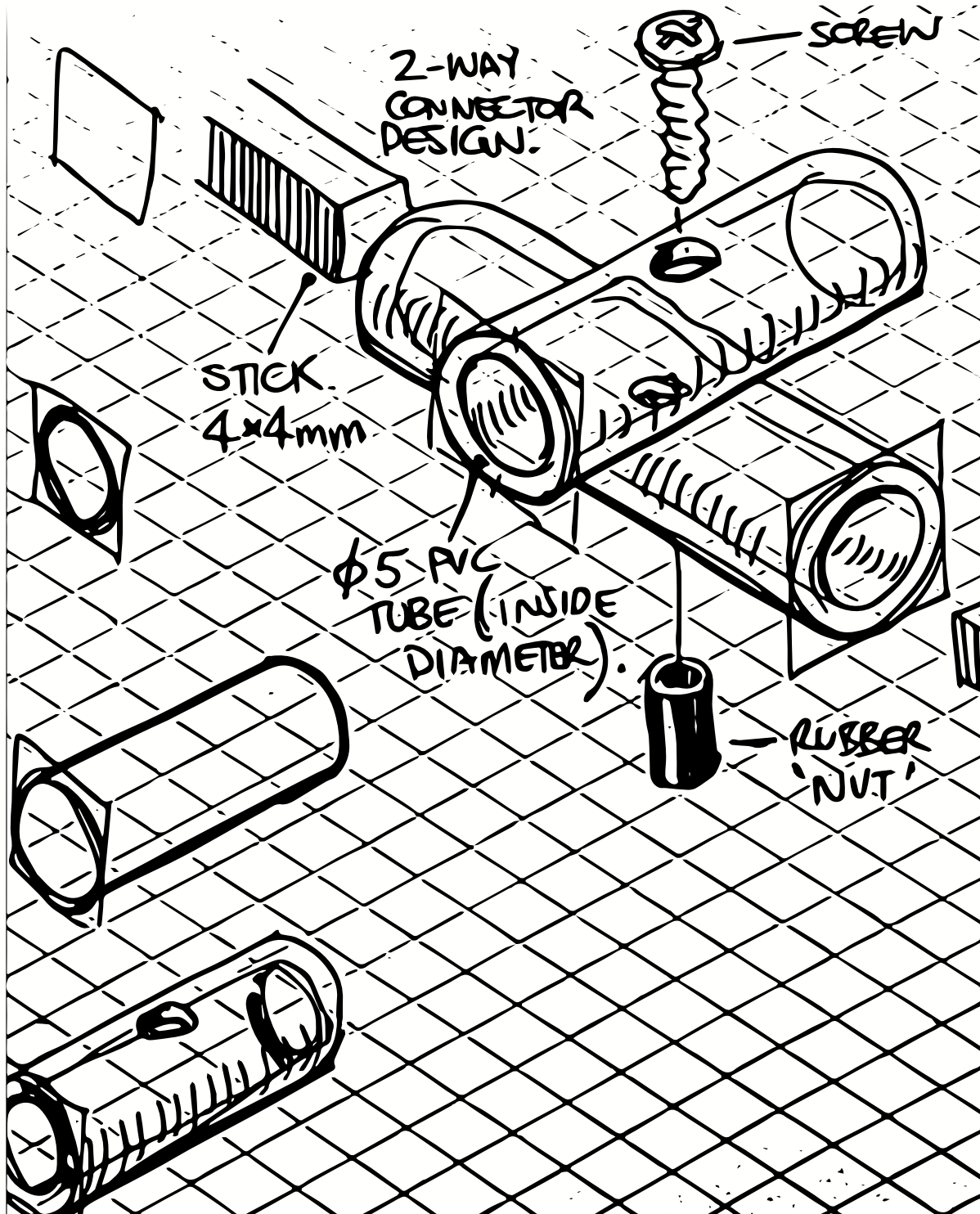



**Activity:** Bring all your design ideas into one final design drawing or blueprint for your experiment, device or environment. This does not need to be a fantastic drawing, it just helps to get to the next stage in the iSTEM process - prototyping. It is a good idea to base your drawing on the materials, parts or lab equipment that you know will be available to use while constructing your prototype.

Info from <http://www.domerama.com/calculators/2v-geodesic-dome-calculator/>  
A "2V dome" means that **two** struts lengths are used in the dome.

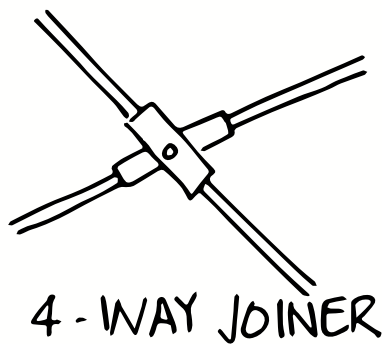

Make 10 of these

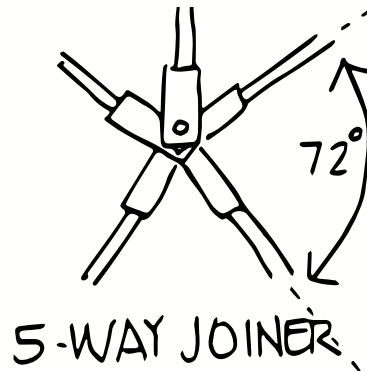

Make 6 of these

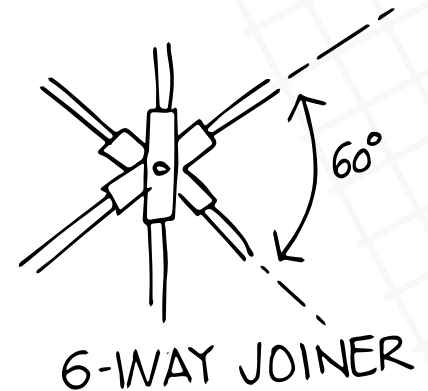

Make 10 of these

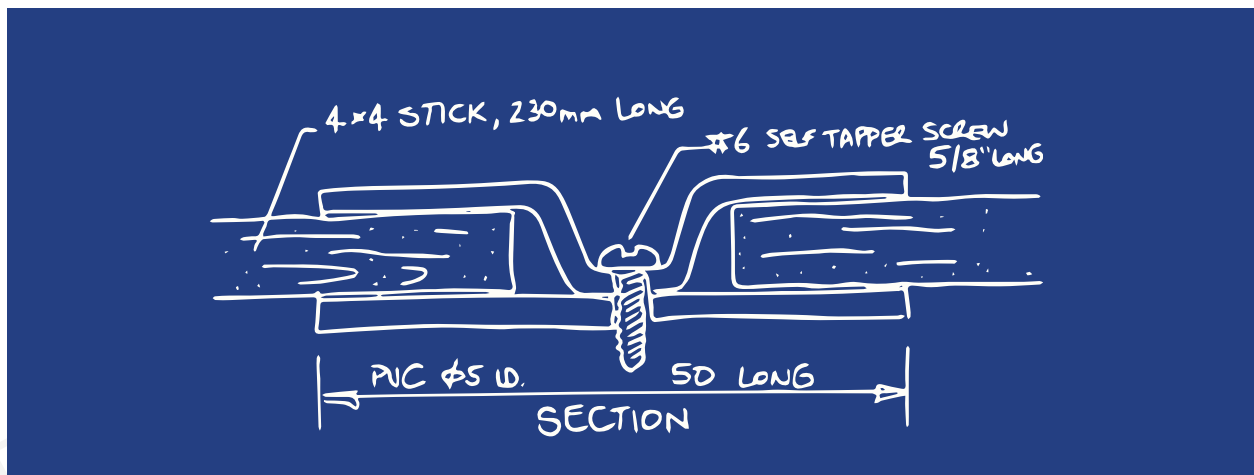

Strut B: 35 of these

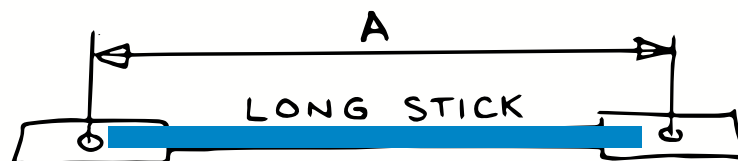

Strut A: 30 of these

